

FULL INVERTER POOL PUMP

ENERGY
EFFICIENT



Neptune
for swimming pools

By **Pool
Pro**

X-PRO

UP TO **15x**
MORE ENERGY
EFFICIENT**

OVER
50%
QUIETER[^]

DC
BRUSHLESS
MOTOR

Wi-Fi
CONTROL

★ ★ ★ ★ ★ ★
6 STAR ENERGY RATING

INVERSilence Tech

SCAN FOR
MORE INFO





Neptune X-Pro Full Inverter Pool Pumps are designed for exceptional energy efficiency and super-quiet operation. Enjoy total control with a real-time power consumption display and a sleek, intelligent full touch controller.

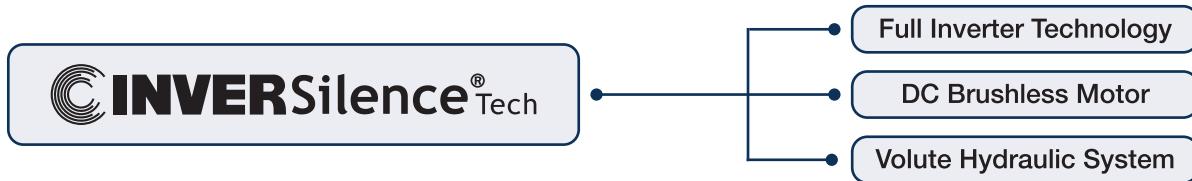

KEY FEATURES FOR ALL MODELS

- ✓ 6 Star Energy Efficiency rating - up to 15x more energy efficient**
- ✓ Full inverter technology - automatically adjusts running capacity between 30~120%
- ✓ DC brushless motor - for super-quiet operation, higher efficiency and longer lifespan of the pump
- ✓ Volute hydraulic system - spiral volute structure lowers water flow turbulence and noise
- ✓ Intelligent full touch controller - easily control and monitor the pump's operation
- ✓ Over 50% quieter[^] - quiet operation down to 33dB(A)
- ✓ Soft start feature - steadily increases power to maximise energy savings
- ✓ 4 timers for daily operation - with multi speed and multi timer function
- ✓ Wi-Fi control and InverFlow App - control your pump anywhere anytime

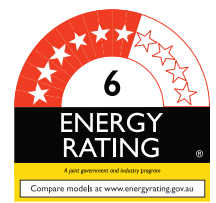

TECHNICAL INFORMATION / PERFORMANCE DATA

Model	Input Power (kW)	Input Power (hp)	Voltage (V/Hz)	Current (A)	Max Flow Rate (L/min)	Flow Rate @ 8m Head (L/min)
NPX1100	0.8	1.0	220-240 / 50/60	3.5	408	312
NPX1500	1.05	1.5		5.3	438	393
NPX2000	1.4	2.0		6.5	488	470
NPX2500	1.75	2.5		8.0	678	603

PRODUCT DIMENSIONS

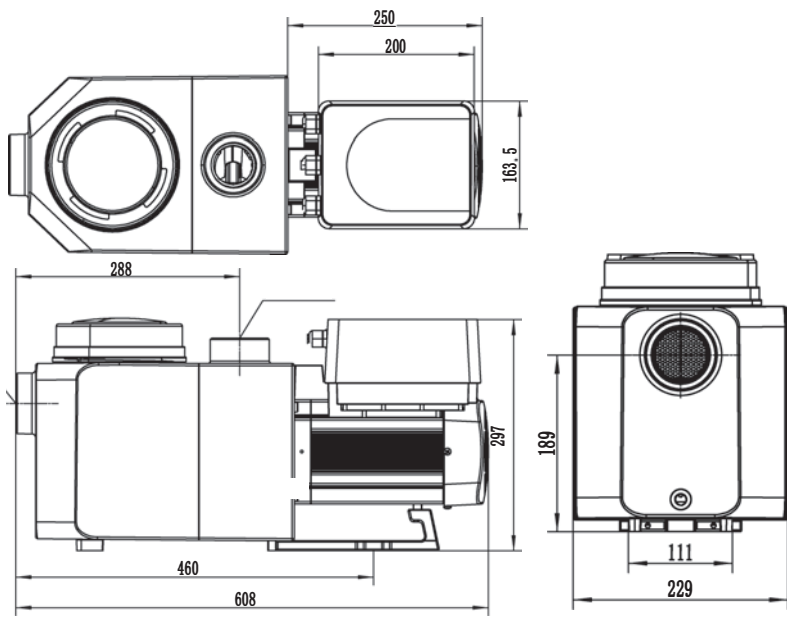

AVAILABLE FROM YOUR LOCAL POOL PRO STOCKIST



**Than regular 1500w single speed pumps. Model NPX1500 @ 8m head.
[^]Than regular single speed pumps. Model NPX1100 (33dB(A)).
 * Warranty: 4 year limited on all parts.